

The PDSP16330 is designed to carry out the coordinate transform $x, y, z \rightarrow r, \theta, \phi$. Many applications in robotics and target positioning require three dimensional transformations of the form $x, y, z \rightarrow r, \theta, \phi$. This application brief shows how the Pythagoras Processor PDSP16330 can be used for three dimensional transforms.

Fig.1 shows a point x, y, z in a three dimensional space. If we move down the z -axis to the point $x, y, 0$, we are at a point whose distance from the origin is $h = \sqrt{x^2 + y^2}$ whose bearing is $\arctan(y/x)$. The distance from the origin to the point x, y, z is therefore given by $r = \sqrt{h^2 + z^2}$ and the elevation of that point given by $\arctan(z/h)$. In this way the three dimensional transform $x, y, z \rightarrow r, \theta, \phi$ has been decomposed into two 2- dimensional transforms which can be carried out by the Pythagoras Processor.

Fig.2 shows the most obvious implementation of a 3-D transform, using two Pythagoras Processors. The first processor is given x, y as its input, providing the bearing and the distance to the point $x, y, 0$. The second processor has z (suitably delayed to match the pipeline delay through the first processor) and h as its inputs giving r and ϕ as its outputs. Output θ from the first processor is delayed so that all three outputs suffer the same pipeline delay.

Fig.3 shows an alternative realisation employing a single Pythagoras Processor. In this case x and y data are input on every other cycle, the alternate cycle inputs being z and h . The z input has a pipeline delay to compensate for the delay on h relative to x and y . The configuration will achieve a throughput of 5MHz, half of the previous circuit.

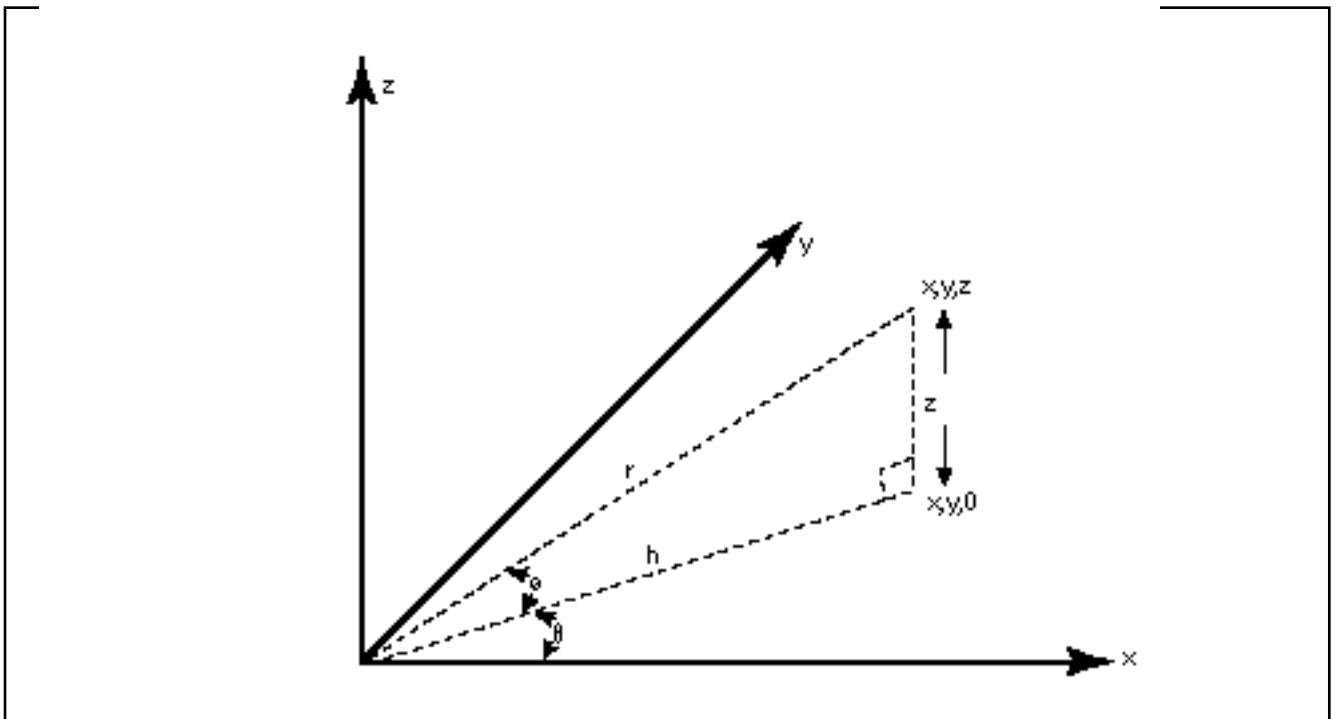

Fig.1

AB17

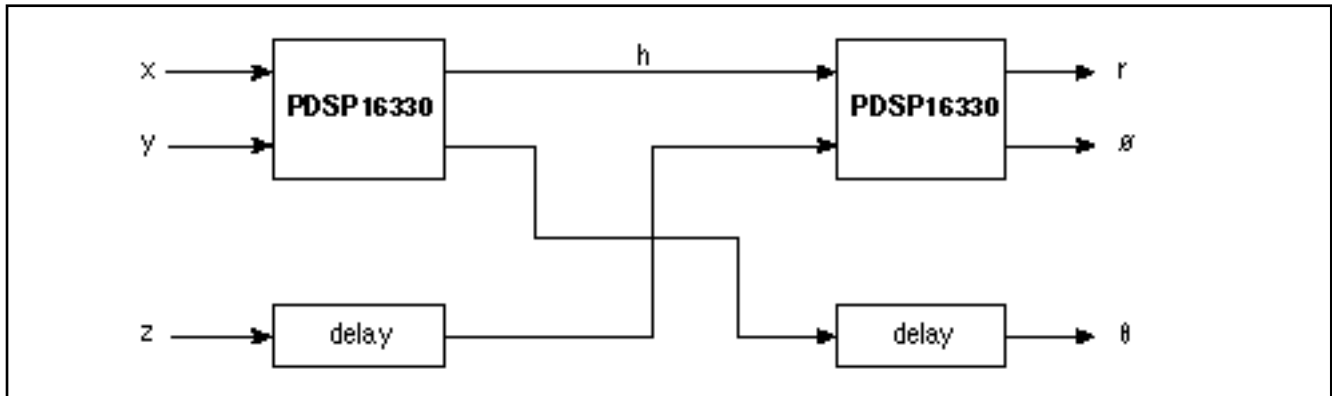

Fig.2

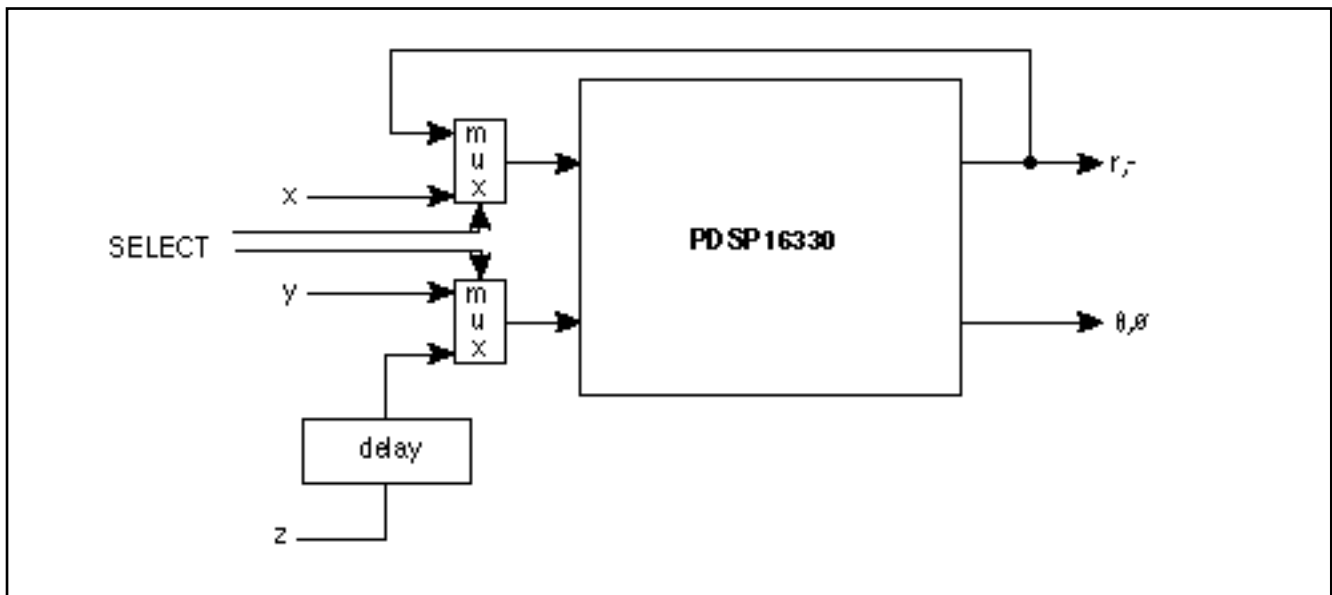

Fig.3



HEADQUARTERS OPERATIONS
MITEL SEMICONDUCTOR
 Cheney Manor, Swindon,
 Wiltshire SN2 2QW, United Kingdom.
 Tel: (01793) 518000
 Fax: (01793) 518411

MITEL SEMICONDUCTOR
 1500 Green Hills Road,
 Scotts Valley, California 95066-4922
 United States of America.
 Tel (408) 438 2900
 Fax: (408) 438 5576/6231

Internet: <http://www.gpsemi.com>
CUSTOMER SERVICE CENTRES

- **FRANCE & BENELUX** Les Ulis Cedex Tel: (1) 69 18 90 00 Fax : (1) 64 46 06 07
- **GERMANY** Munich Tel: (089) 419508-20 Fax : (089) 419508-55
- **ITALY** Milan Tel: (02) 6607151 Fax: (02) 66040993
- **JAPAN** Tokyo Tel: (03) 5276-5501 Fax: (03) 5276-5510
- **KOREA** Seoul Tel: (2) 5668141 Fax: (2) 5697933
- **NORTH AMERICA** Scotts Valley, USA Tel: (408) 438 2900 Fax: (408) 438 5576/6231
- **SOUTH EAST ASIA** Singapore Tel:(65) 3827708 Fax: (65) 3828872
- **SWEDEN** Stockholm Tel: 46 8 702 97 70 Fax: 46 8 640 47 36
- **TAIWAN, ROC** Taipei Tel: 886 2 25461260 Fax: 886 2 27190260
- **UK, EIRE, DENMARK, FINLAND & NORWAY**
 Swindon Tel: (01793) 726666 Fax : (01793) 518582

These are supported by Agents and Distributors in major countries world-wide.

© Mitel Corporation 1998 Publication No. AB17 Issue No. 2.1 July 1993

TECHNICAL DOCUMENTATION – NOT FOR RESALE. PRINTED IN UNITED KINGDOM

This publication is issued to provide information only which (unless agreed by the Company in writing) may not be used, applied or reproduced for any purpose nor form part of any order or contract nor to be regarded as a representation relating to the products or services concerned. No warranty or guarantee express or implied is made regarding the capability, performance or suitability of any product or service. The Company reserves the right to alter without prior notice the specification, design or price of any product or service. Information concerning possible methods of use is provided as a guide only and does not constitute any guarantee that such methods of use will be satisfactory in a specific piece of equipment. It is the user's responsibility to fully determine the performance and suitability of any equipment using such information and to ensure that any publication or data used is up to date and has not been superseded. These products are not suitable for use in any medical products whose failure to perform may result in significant injury or death to the user. All products and materials are sold and services provided subject to the Company's conditions of sale, which are available on request.

All brand names and product names used in this publication are trademarks, registered trademarks or trade names of their respective owners.